

Functional Storage Rigs

Unveil the ultimate fusion of practicality and organization with our cutting-edge creation! Introducing our latest innovation—a game-changing product that seamlessly blends functional training with integrated storage solutions. Prepare to elevate your fitness space with boundless possibilities! The Functional Storage rigs makes a bold statement with its distinctive design and unparalleled versatility. Not only does it provide an optimized space for functional training, but it also ingeniously incorporates storage rack functionalities. With the flexibility to connect extension modules, you have the power to expand endlessly, effortlessly creating a vast storage rack and an expansive functional training area. Experience a new era of efficiency and convenience. It's not just a product; it's a paradigm shift in fitness equipment, designed to enhance every aspect of your workout environment.



Wall Based Design



Flexible Extension



3mm Thick Tubing



Intergrated Storage

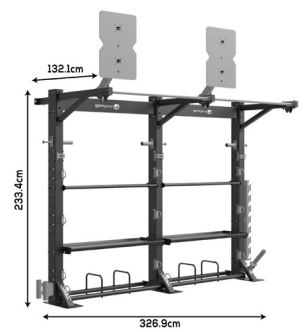
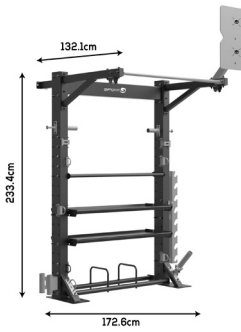
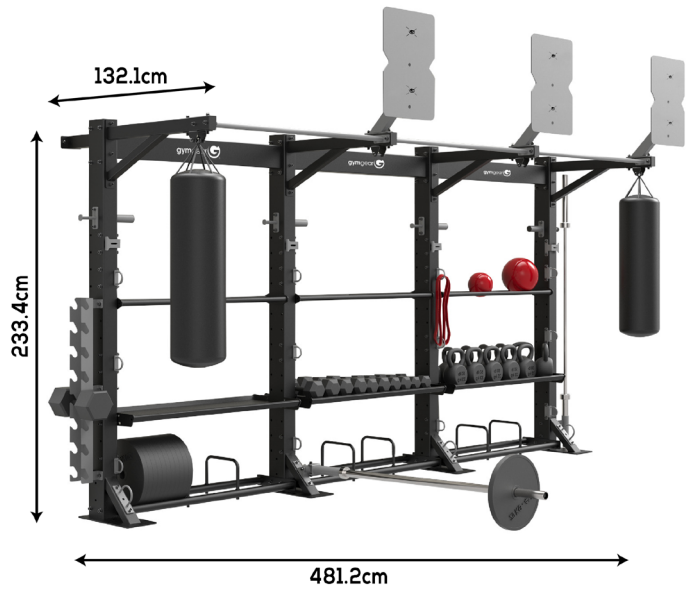

Technical Specifications

Dimensions (Per Single Unit)	L 132.1 x W 172.6 x H 233.4 cm L 60.7 x W 67.9 x H 91.8 inches
Tubing	3mm
Accessories Available	Training Plate Storage, Dumbbell/Kettlebell Storage, Ball Storage, Barbell Storage, Wall Ball Target, Landmine Attachment, Vertical Dumbbell Storage
Total Height with Wall Ball Target	315.5cm / 124.2 inches (Wall Ball Target Height: 82.1cm)

Key Features

Durable Design		•
Flexible Extension		•
Multiple Storage Configurations		•
Storage is Intergrated		•
Wall Mounted		•
Functional Training + Storage		•